

Preparing a Drinking Water Quality Management Plan Supporting Information

September 2010

Prepared by:

Urban Water Policy and Management

Department of Environment and Resource Management

© State of Queensland (Department of Environment and Resource Management) 2010

This document has been prepared with all due diligence and care, based on the best available information at the time of publication. The department holds no responsibility for any errors or omissions within this document. Any decisions made by other parties based on this document are solely the responsibility of those parties. Information contained in this document is from a number of sources and, as such, does not necessarily represent government or departmental policy.

If you need to access this document in a language other than English, please call the Translating and Interpreting Service (TIS National) on 131 450 and ask them to telephone Library Services on +61 7 3224 8412.

This publication is available in alternative formats (including large print and audiotape) on request for people with a vision impairment.

Contact (07) 322 48412 or email <library@derm.qld.gov.au>

September 2010

#29466

Contents

1	Foreword	1
2	Useful references	2
2.1	Australian Drinking Water Guidelines	2
2.2	Hazard Analysis Critical Control Point	2
2.3	AS/NZS ISO 31000:2009 Risk Management—principles and guidelines	2
2.4	The Cooperative Research Centre for Water Quality and Treatment—A Guide to Hazard Identification & Risk Assessment for Drinking Water Supplies—Research Report No 11, 2004.....	2
2.5	ISO 22000:2005 Food safety management systems—requirements for any organisation in the food chain.....	3
2.6	National Health and Medical Research Council Community Water Planner	3
2.7	World Health Organisation water safety plans	3
3	Drinking Water Quality Management Plan process	4
4	Examples of drinking water supply schematic layouts.....	5
5	Examples of potential sources of hazards and hazardous events.....	8
5.1.1	Australian Drinking Water Guidelines	8
5.1.2	CRC for Water Quality and Treatment: A Guide to Hazard Identification & Risk Assessment for Drinking Water.....	11
6	Examples of preventive measures	15
7	Example of risk methodology	17
8	Examples of operation and maintenance procedures.....	19
9	References	21

1 Foreword

The following document accompanies the Drinking Water Quality Management Plan Guideline to assist providers when developing a drinking water quality management plan. It provides lists of examples and further sources of information that may be referenced by the provider in preparing their plan.

It should be noted that the supporting information provided in this document are examples only. It is the responsibility of the provider to ensure legislative requirements of the *Water Supply (Safety and Reliability) Act 2008* are met.

2 Useful references

This section provides useful references for the preparation of a drinking water quality management plan (the plan), but should not be considered an exhaustive list.

2.1 Australian Drinking Water Guidelines

The Australian Drinking Water Guidelines (ADWG) incorporate the framework for the management of drinking water quality, based on a risk management approach, and provide guidance on what constitutes good quality drinking water. The ADWG are built around 12 elements, which overlap with concepts also found in the Hazard Analysis Critical Control Point (HACCP), ISO 9001 Quality Management System and AS/NZS ISO 31000:2009 Risk Management. The ADWG specifically apply these concepts in a drinking water supply context. It is expected the ADWG could be used as both an additional source of information and guidance for providers. For example:

- Chapter 3 provides a comprehensive overview of the 12 elements
- Chapters 9 and 10 provide guidance on monitoring programs.

The ADWG Appendix provides additional guidance on:

- the assessment of the drinking water supply system (element 2)
- preventive measures for drinking water quality management (element 3)
- tables A2 to A7 provide information on potential hazards and hazardous events, risk assessment and preventive measures
- section A9 lists additional sources of detailed technical guidance.

2.2 Hazard Analysis Critical Control Point

The HACCP system is extensively used in the food industry and has become an internationally recognised risk management system. The application of the HACCP system to drinking water supplies has received increasing recognition due to parallel issues in food and drinking water supply. While HACCP is aligned to the treatment component of drinking water supply, its application may not transfer as easily to the areas of catchment and distribution systems.

2.3 AS/NZS ISO 31000:2009 Risk Management—principles and guidelines

AS/NZS ISO 31000:2009 presents the generic principles, framework and process to be applied to risk management for any undertaking or organisation. The principles and framework relate to the values and internal arrangements that embed risk management within an organisation, while the process sets out the basic steps for a logical and consistent methodology which can be adapted to most situations. AS/NZS ISO 31000:2009 supersedes AS/NZS 4360:2004.

AS/NZS ISO 31000:2009 also defines fundamental risk management terms such as event, consequence, likelihood, risk, residual risk, etc. Because of its intended generic nature, and applicability to either positive or negative risks, the standard uses the term event rather than hazard or hazardous event. In the context of the plan, the provider will be concerned with negative risks and therefore an event will actually be a hazardous event.

AS/NZS ISO 31000:2009 does not provide tools for the analysis of specific hazards or the risks they might pose, for example, analysing the risks posed by physical, chemical or microbiological hazards when they are present in drinking water. Risk managers need to rely on the services of experienced and qualified people, using accepted industry/discipline-specific methods.

Effective risk management requires identification of all potential hazards and hazardous events and an assessment of the level of risk associated with each hazard or hazardous event.

2.4 The Cooperative Research Centre for Water Quality and Treatment—A Guide to Hazard Identification & Risk Assessment for Drinking Water Supplies—Research Report No 11, 2004

The Cooperative Research Centre for Water Quality and Treatment—A Guide to Hazard Identification & Risk Assessment for Drinking Water Supplies—Research Report No 11, 2004 complements the ADWG and provides additional guidance for assessment of the drinking water supply system (element 2). In particular, it provides guidance on conducting hazard identification and risk assessment. This guide may assist providers in understanding their water supply system, the hazards and events that can compromise drinking water quality and the preventive measures necessary for ensuring safe drinking water.

2.5 ISO 22000:2005 Food safety management systems—requirements for any organisation in the food chain

ISO 22000:2005 is an international standard which specifies the requirements for a food safety management system. It includes the following elements:

- interactive communication
- system management
- HACCP principles.

ISO 22000:2005 can provide further information and guidance on communication and the principles of the HACCP system.

Further information on the ADWG, HACCP and AS/NZS ISO 31000:2009, and how they relate to the plan, can be found in section 3.3 of the Drinking Water Management Plan Guideline.

2.6 National Health and Medical Research Council Community Water Planner

The National Health and Medical Research Council (NHMRC) Community Water Planner is an electronic decision support tool to assist managers of small community drinking water supplies to implement the ADWG framework. This is a potentially useful resource for small providers with relatively simple schemes and can provide assistance and guidance on the identification of generic hazards, risks and preventive measures. It can be used to produce a table of operational, corrective and verification monitoring activities that may provide a useful starting point for the development of a risk-based monitoring program and to commence the development of the plan.

The NHMRC Community Water Planner is available on the Australian Government National Health and Medical Research Council website at <www.nhmrc.gov.au>.

2.7 World Health Organisation water safety plans

The World Health Organisation (WHO) has developed an approach to managing drinking water quality from catchment to consumer based on using water safety plans. This approach is primarily aimed at rural and remote communities. It draws on many of the principles and concepts from other risk management approaches, in particular the multiple barrier approach and HACCP, as used in the food industry.

The WHO guidelines Water safety plans: Managing drinking-water quality from catchment to consumer and the Water Safety Plan Manual Step by Step Risk Management for Drinking Water Supplies may also be useful resources.

Both these documents are available on the WHO website at <www.who.int>.

3 Drinking Water Quality Management Plan process

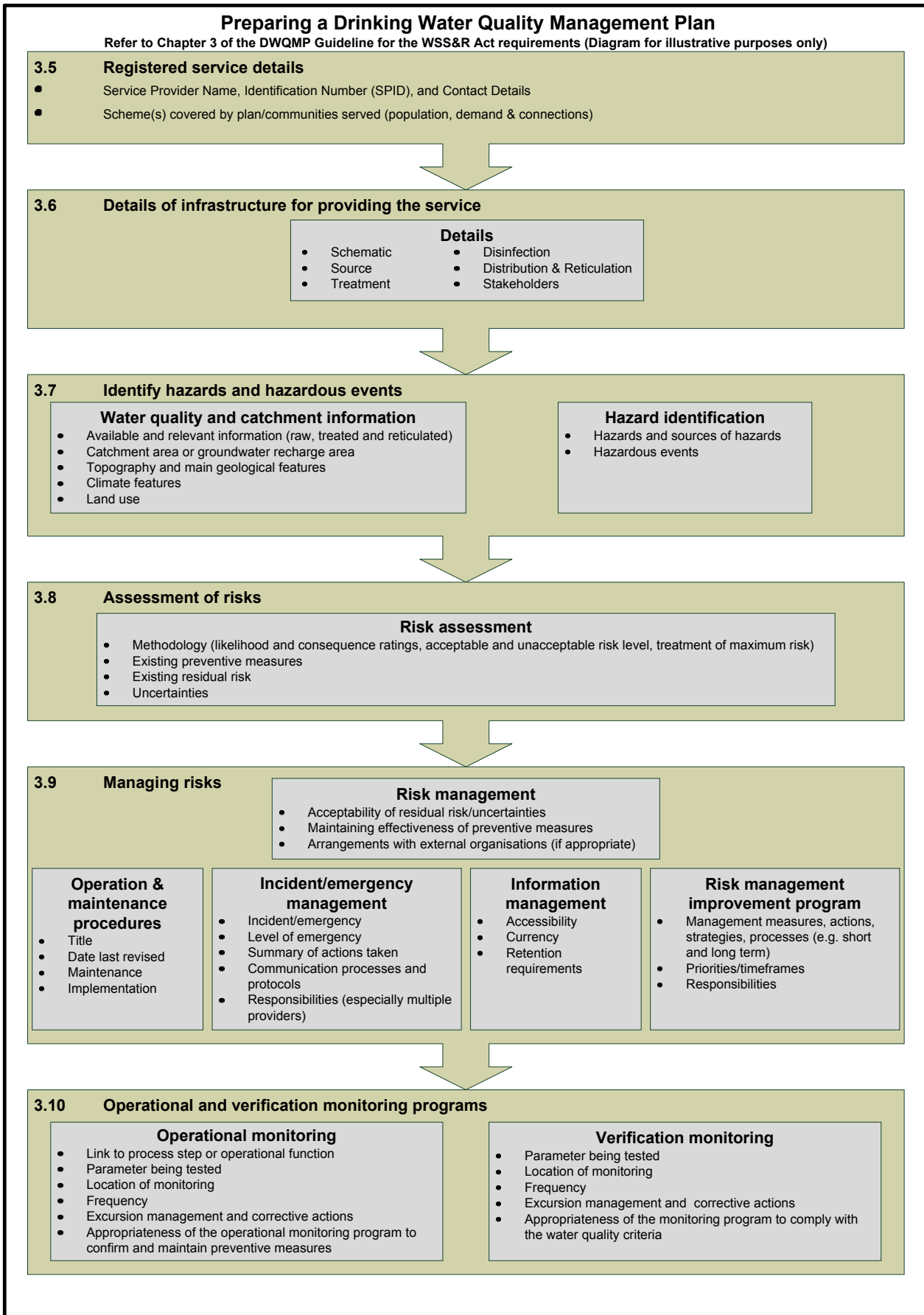

4 Examples of drinking water supply schematic layouts

Note: The following diagrams are examples only. It is the responsibility of the provider to ensure the legislative requirements are met.

Diagram 1: Schematic of a larger provider's overall water supply scheme

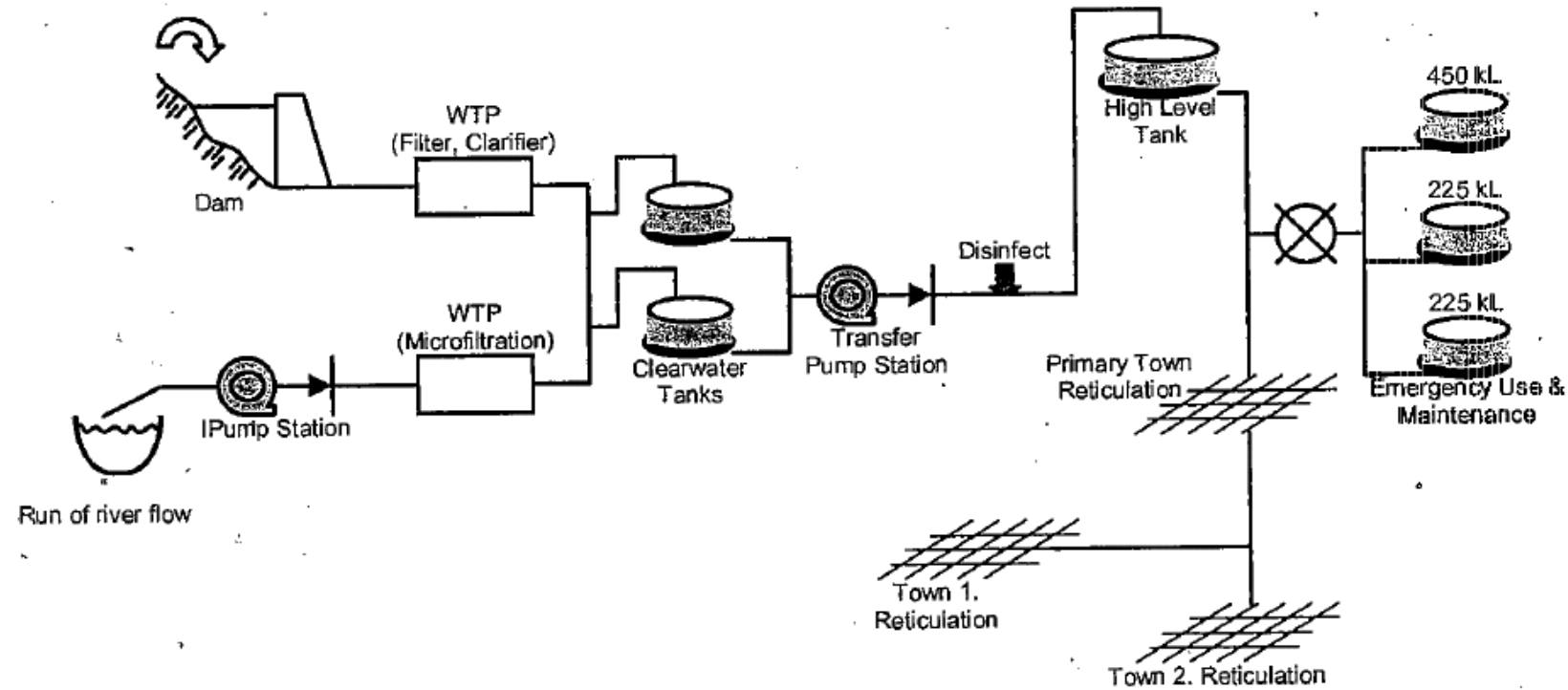

Source: Water Quality Research Australia, Research Report No 78

Diagram 2: Schematic of a smaller provider's overall water supply scheme

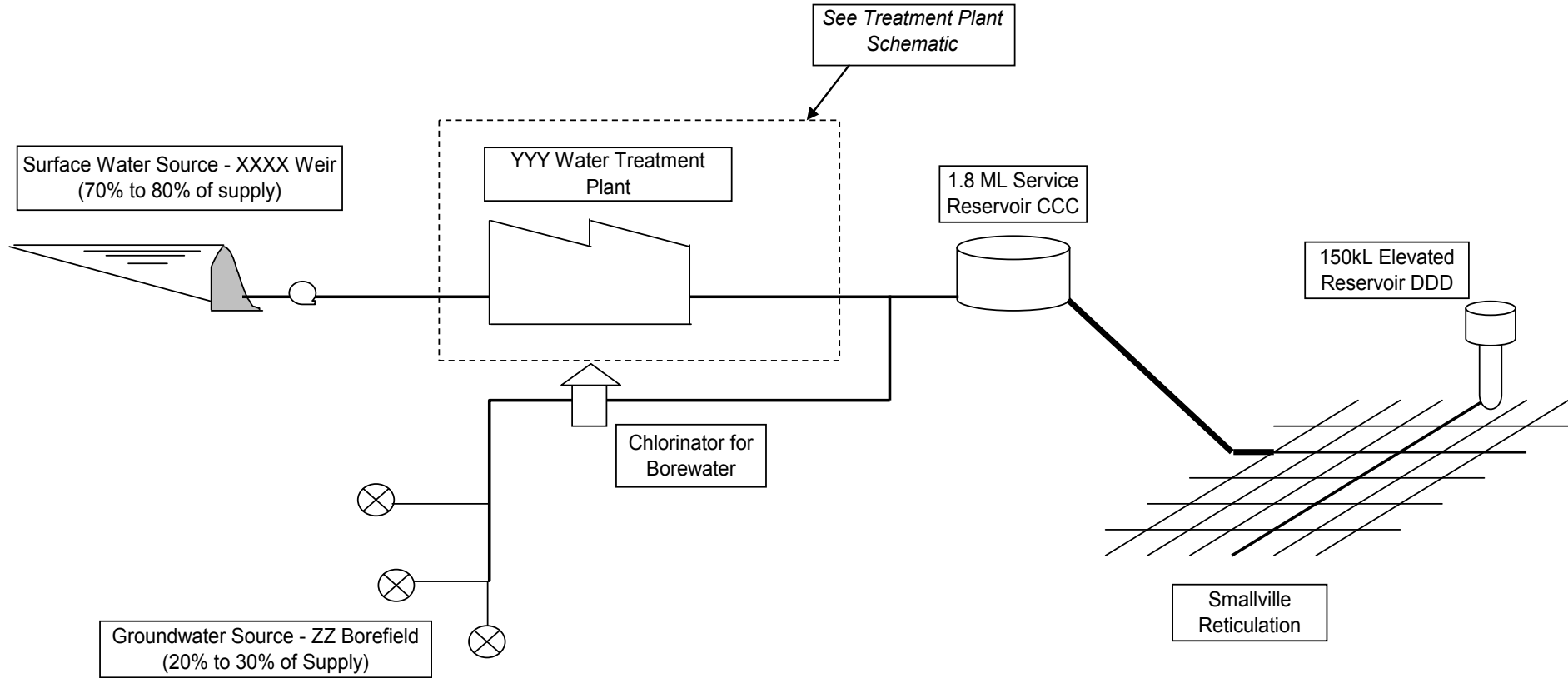
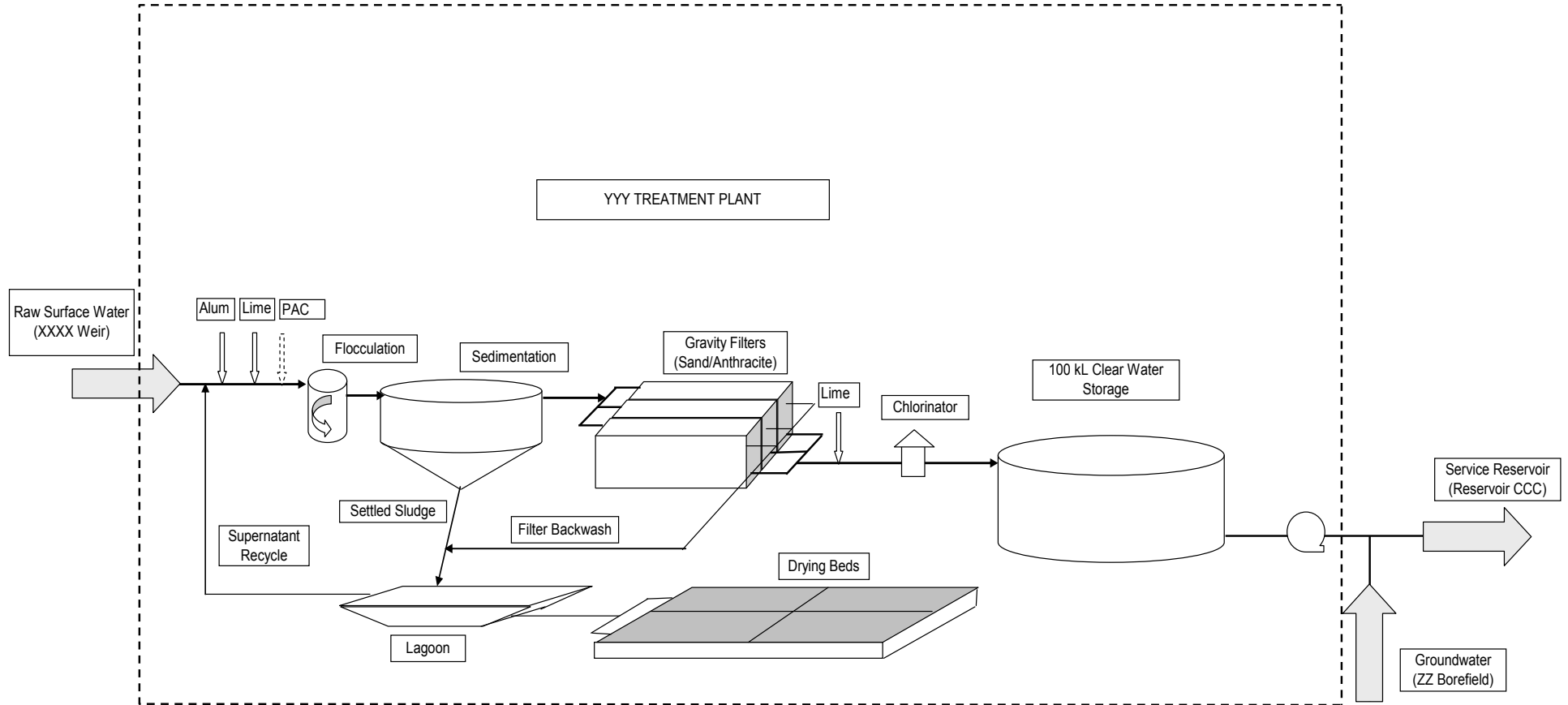

Diagram 3: Schematic of a small treatment plant



5 Examples of potential sources of hazards and hazardous events

There are a number of alternative approaches to the process of identifying hazards and hazardous events. All are equally valid, as long as they are applied consistently across equivalent drinking water service. The following section provides examples on potential sources of hazards, sourced from the ADWG and the Cooperative Research Centre (CRC) for Water Quality and Treatment.

Note: The following tables are examples only. It is the responsibility of the provider to ensure the legislative requirements are met.

5.1.1 Australian Drinking Water Guidelines

The following table provides examples of sources and potential hazards. The table refers to information obtained from the ADWG 2004—Appendix A4; Table A2.

Table 1: Examples of sources and potential hazards^a

Potential sources	Potential hazard
Septic tanks	Pathogens ^b , nitrates/nitrites
Sewage treatment plants	Pathogens, nutrients ^c
Animal husbandry	Pathogens, nutrients ^c , turbidity ^c , colour ^c
Horticulture	Pesticides, fertiliser nutrients ^c , turbidity ^c , colour ^c
Rural stormwater	Pathogens, turbidity ^c , colour ^c
Forestry	Pesticides, turbidity ^c , colour ^c
Industry	Heavy metals, organic chemicals including halogenated organics; specific industries can be associated with specific types of contaminants (e.g. arsenic and copper associated with wood preserving, cadmium and chromium with electroplating and chromium with leather tanning)
Mining	Acid mine wastes from pyrites tailings can release and transport metals such as aluminium, iron and manganese; other naturally occurring metals such as cadmium and copper can also be leached; arsenic can be associated with old goldfield areas
Urban stormwater	Lead and zinc from roads, turbidity ^c , colour ^c , petrol/oil products, microorganisms from pets (lower range of pathogens than from humans or livestock waste)
Stormwater/sewer overflows	Pathogens, nutrients ^c , turbidity ^c , colour ^c

a – Human and animal waste represent the largest sources of potential hazards in drinking water. Both can include high numbers of enteric pathogens and large amounts of nutrients. Due to the scale of primary production in Australia, the total amount of livestock waste would greatly exceed the amount of human waste.

b – The potential range of pathogens present will vary according to the type of waste involved. Many enteric pathogens, and in particular viruses and protozoa, infect only one species. In general, human enteric viruses are only carried and excreted by humans. Human infectious *Cryptosporidium parvum* can be carried by humans and livestock, but the current state of knowledge suggests that the species of *Cryptosporidium* that infect birds do not infect humans.

c – Potential indirect hazards.

The following table refers to hazardous events and their potential sources. The table refers to information obtained from the ADWG 2004—Appendix A4; Table A3

Table 2: Examples of hazardous events and their potential sources

Catchments and groundwater systems	
<ul style="list-style-type: none"> • Rapid variations in raw water quality • Sewage and septic system discharges • Industrial discharges • Chemical use in catchment areas (e.g. use of fertilisers and agricultural pesticides) • Major spills and accidental spillage • Public roads • Human access (recreational activity) • Wildlife (native and feral) • Unrestricted livestock • Inadequate buffer zones • Surrounding land use (e.g. animal husbandry, agriculture, forestry, industrial area, waste disposal, mining) • Changes in surrounding land use 	<ul style="list-style-type: none"> • Poorly vegetated riparian zones, failure of sediment traps and soil erosion • Stormwater flows and discharges • Existing or historical waste-disposal or mining sites/or contaminated sites and hazardous wastes • Unconfined and shallow aquifers • Groundwater under direct influence of surface water • Inadequate well-head protection and unhygienic practices • Uncased or inadequately cased bores • Saline intrusion of coastal aquifers • Contaminated aquifers • Climatic and seasonal variations (e.g. heavy rainfalls, droughts) • Bushfires, natural disasters, sabotage
Storage reservoirs and intakes	
<ul style="list-style-type: none"> • Open reservoirs and aqueducts, uncovered storages • Human access or/absence of exclusion areas around shorelines • Animal access including birds and vermin • Short-circuiting of reservoir • Depletion of reservoir storage • No selective withdrawal • No alternative water sources • Unsuitable intake location • Cyanobacterial blooms 	<ul style="list-style-type: none"> • Stratification • Soil erosion • Inadequate buffer zones and vegetation • Climatic and seasonal variations (e.g. heavy rainfalls, droughts) • Public roads/accidental spillage • Failure of alarms and monitoring equipment • Bushfires and natural disasters • Sabotage
Treatment systems	
<ul style="list-style-type: none"> • Significant flow variations through water treatment system • Incapable equipment or unit processes • Inadequate backup • Inappropriate treatment processes • Process control incapability or operational inflexibility • Use of unapproved or contaminated water treatment chemicals and materials • Chemical dosing failures • Inadequate mixing 	<ul style="list-style-type: none"> • Failure of dosing equipment • Inadequate filter operation and backwash recycling • Ineffective disinfection • Equipment malfunctions • Poor reliability of processes • Failure of alarms and monitoring equipment • Power failures • Sabotage and natural disasters • Formation of disinfection by-products

Service reservoirs and distribution systems	
<ul style="list-style-type: none"> • Open reservoirs and aqueducts/uncovered storages and unprotected pipe system • Human access, absence of exclusion areas around shorelines • Animal access including birds and vermin • Short-circuiting of reservoir, stagnation zones • Build-up of sediments and slimes • Inappropriate materials and coatings or material failure • Aged pipes, infrastructure • Corrosion of reservoirs and pipe system • Mixing of different source waters • Infiltration and ingress of contamination from cross-connections, backflow (soil and groundwater) 	<ul style="list-style-type: none"> • Biofilms, sloughing and re-suspension, regrowth • Pipe bursts or leaks • Inadequate repair and maintenance, inadequate system flushing and reservoir cleaning • Commissioning new mains • Inadequate disinfection after construction, repairs • Flow variability, inadequate pressures • Treatment dosing failure • Inadequate maintenance of chlorine residual • Formation of disinfection by-products • Failure of alarms and monitoring equipment • Sabotage and natural disasters
Consumers	
<ul style="list-style-type: none"> • Potential consumer misuse • Leaching of metals 	<ul style="list-style-type: none"> • Inappropriate plumbing and construction materials

5.1.2 CRC for Water Quality and Treatment: A Guide to Hazard Identification & Risk Assessment for Drinking Water

The CRC for Water Quality and Treatment: A Guide to Hazard Identification & Risk Assessment for Drinking Water includes an Index of Hazard Fact Sheets that provides 36 examples of hazards, grouped under six source headings. Possible preventive measures for managing the risk are also suggested. The following tables refer to information from Index of Hazard Fact Sheets no 2 and 18.

Note: The following tables are examples only. It is the responsibility of the provider to ensure the legislative requirements are met.

Table 3: Examples of environmental hazards within catchments

Source of hazard/event	Typical hazards	Factors to consider in assessing likelihood and severity	Typical preventive measures	Suggestions for consideration
Bushfires	<ul style="list-style-type: none"> • Turbidity—from particulate fallout • Turbidity—from erosion • Microbiological contamination—from dead animals • Chemical contamination—from fire retardants 	<ul style="list-style-type: none"> • Human activities within the catchment and surrounding areas which could cause fires (e.g. roads, camping, industrial or urban development) • Distribution of fire prone areas within the catchment and their proximity to reservoirs and waterways • Fire fuel levels within the catchment • Presence of fire breaks • Catchment particularly prone to fire 	<ul style="list-style-type: none"> • Fire breaks • Coordinated fire management plan • Restricted use of fire retardant chemicals 	<ul style="list-style-type: none"> • Review occurrence and extent of bushfires • Review preventive measures and effectiveness • Review the impact of long-term fire retardant measures
Storms	<ul style="list-style-type: none"> • Turbidity—from erosion • Microbiological contamination • See fact sheet on ‘Residence Time, Short Circuiting and Stratification of Reservoirs’ (Refer Hazard Sheet No 11) 	<ul style="list-style-type: none"> • Storm event probability • Flow resulting from major storm compared with the reservoir level • Flow response characteristics of catchment • Presence of sediment traps (natural or artificial) • Capacity of buffer zones in reducing sediment and nutrient loads in major storms • Types of vegetation and ground cover within catchment 	<ul style="list-style-type: none"> • Sediment traps • Buffer zones around reservoirs and waterways • Flood mitigation/retardation basins • Extraction management • Alternate water source/use of water storage 	<ul style="list-style-type: none"> • Determine quality of stormwater during storm events and assess significance with respect to receiving water • Review effectiveness of preventive measures

Source of hazard/event	Typical hazards	Factors to consider in assessing likelihood and severity	Typical preventive measures	Suggestions for consideration
Wildlife—includes feral, native, stray and unfenced farm animals	<ul style="list-style-type: none"> • Microbiological contamination—from waste and dead animals • Turbidity—from erosion due to overgrazing and animal tracks • Cyanobacteria toxins • Taste and odour compounds—from algae • See ‘Pesticide/herbicide spraying’ re baiting (Fact Sheet 1) 	<ul style="list-style-type: none"> • Frequency of detection of high risk feral animals (e.g. pigs, cattle, seagulls, deer) • Numbers of dead animals found in aqueducts, watercourses and reservoirs • Numbers of water birds roosting, especially near diversion points • Shoreline vegetation disturbance and animal dung density 	<ul style="list-style-type: none"> • Patrols to remove dead animals • Feral/native animal culls • Baiting • Fencing of catchment areas • Screens at water supply inlet points • Aqueducts which animals can easily get out of 	<ul style="list-style-type: none"> • Periodic wildlife surveys • Review effectiveness of feral animal prevention programs • Review structures (e.g. aqueducts), to ensure animals can get out if they fall in
Geology—in relation to groundwater	<ul style="list-style-type: none"> • Turbidity—from dissolved minerals (e.g. iron) • Chemical contamination—from arsenic leaching and manganese (causing staining), minerals 	<ul style="list-style-type: none"> • Location, alignment and characteristics of aquifers within the catchment • Presence of potentially hazardous minerals within the catchment • Quality of groundwater • Relative flow of groundwater • Variability of groundwater quality and flow • Depth to water table 	<ul style="list-style-type: none"> • Water chemistry monitoring • Hydrology monitoring • Avoidance of high arsenic or manganese content geology • Aeration for stripping sulphides • Removal of iron, manganese or arsenic contaminations 	<ul style="list-style-type: none"> • Review geology and quality of groundwater and surface water (e.g. metals, sulphides) with respect to impact on water quality

Table 4: Examples of hazards with WTP¹ design capacity—iron and manganese

Source of hazard/event	Typical hazards	Factors to consider in assessing likelihood and severity	Typical preventive measures	Suggestions for consideration
<p>Iron (Fe) or manganese (Mn) in raw water:</p> <ul style="list-style-type: none"> • Exceedance of design upper limit • Unexpected increase not detected • Normal treated water target wrongly specified 	<ul style="list-style-type: none"> • Iron, manganese—resulting in black water, colour after chlorination, stained laundry, off tastes • Increase in chloramine or chlorine decay rate—low residuals at outer areas of distribution system • Turbidity—from build up of slimes / biofilms in pipes triggering high turbidity events in high flows 	<ul style="list-style-type: none"> • Ability to detect continuously • Rate of change in Mn/Fe concentration • Duration of high Mn/Fe concentration • Magnitude of concentration • Ability to remove by treatment, e.g. Oxidants and pH control then filtration or DAF • Ability to stop plant • Availability of alternative supply • History and frequency of relevant complaints (e.g. stained laundry, high colour, taste and odour) • Extent of downstream effects and issues (e.g. post chlorination causing colour problems) • Length of pipes in distribution system and extent of biofilm growth • Ability to re-disinfect in outer distribution areas • Customer outage, number of customers affected • Sensitivity of customers, e.g. hospitals, beverage manufacturers • Legal responsibility and liability • See fact sheets 1–13 regarding catchments and reservoirs to determine 	<ul style="list-style-type: none"> • Oxidation by permanganate and pre-lime, then alum or iron coagulation, then filter • Alternative supply • Chloramination • Decrease plant flow rate • Plant shutdown • Aeration of service reservoir • Raise selective withdrawal outlet at supply dam • pH control at oxidant dose point • Mn/Fe monitoring and alarm at plant inlet 	<p>Ensure the following have been considered and assessed:</p> <ul style="list-style-type: none"> • raw water/filtered water monitoring for Fe/Mn (e.g. continuous with high level alarm) • remote control of oxidant and pre lime dose and dose points • upstream preventive measures (e.g. selective near-surface withdrawal, select sources) • treatment reliability (e.g. duty/standby dosing) • conditioning of filters (e.g. post lime plus chlorine before filters) <p>Monitor customer complaints and assess complaint types to identify Fe/Mn problems e.g.:</p> <ul style="list-style-type: none"> • swimming pools turning yellow after addition of chlorine • stained laundry • black water <p>Review design contingencies (e.g. temporary or permanent dosing facilities at WTP)</p> <p>Establish suitable targets and critical limits</p> <p>Encourage research and development of treatment process, Fe and Mn reduction, control and impacts on pipe network</p> <p>Ensure appropriate protocols and operational procedures exist for:</p> <ul style="list-style-type: none"> • using alternative supplies

¹ Water treatment plant

Source of hazard/event	Typical hazards	Factors to consider in assessing likelihood and severity	Typical preventive measures	Suggestions for consideration
		upstream Fe and Mn risks		<ul style="list-style-type: none"> • automatic plant shutdown • reduced plant flow • remote plant operation • start up of required additional oxidation processes • incident management • recording of incidents • notification of potentially affected sensitive customers

6 Examples of preventive measures

Prevention is an essential feature of effective drinking water quality management. Preventive measures must be identified for the risks that may affect the supply of drinking water and hence public health.

For example, significant risks would require regular monitoring and sufficient preventive measures to reduce the risks to acceptable levels. Lower priority risks may not require mitigation in the short-term and the risk management approach may involve occasional monitoring and visual inspections.

In this context, preventive measures are those actions, activities and processes that are used to prevent hazards from occurring or reduce the risk to acceptable levels.

A multiple barrier approach should be a key consideration when identifying preventive measures. This will ensure the failure of one barrier will be compensated for by the others. The types of barriers and range of preventive measures need to be appropriate for each water supply and will be influenced by the catchment characteristics and source water.

Table 5 provides examples of preventive measures from catchment to consumer. This table has adapted information obtained from the ADWG Appendix A6, Table A7.

Note: The following table is an example only. It is the responsibility of the provider to ensure the legislative requirements are met.

Table 5: Examples of preventive measures

Scheme component	Preventive measures to reduce risks to drinking water quality
Catchment/source water	<ul style="list-style-type: none"> • Selection of an appropriate source water (where alternatives exist) • Catchment management plan • Land use planning and control • Use of planning and environmental regulations to regulate potential water polluting developments (e.g. urban, agricultural, industrial, mining and forestry) • Exclusions or limitations of uses (e.g. access restrictions and agriculture) • Pollution control • Regulation of community and on-site wastewater treatment and disposal systems • Stormwater interception • Protection of waterways (e.g. fencing out livestock, management of riparian zones) • Protecting the groundwater recharge area • Use of industry codes of practice and best practice management
Surface water sourcing infrastructure (e.g. dams and storages)	<ul style="list-style-type: none"> • Mixing or de-stratification of storage • Excluding or restricting human, domestic animal and livestock access • Diversion of local stormwater flows • Selective use of multiple extraction points within a single water body to protect against localised contamination (surface water) • Flexibility in the selection of water for treatment and supply where a number of water sources are available
Groundwater sourcing infrastructure (e.g. bores)	<ul style="list-style-type: none"> • Protecting the aquifer and the local area around the borehead from contamination • Protecting the source aquifer by ensuring the integrity of the bore casing • Flexibility in the selection of water for treatment and supply where a number of water sources are available

Scheme component	Preventive measures to reduce risks to drinking water quality
Treatment	<ul style="list-style-type: none"> • Choice of appropriate treatment processes (e.g. coagulation, flocculation, sedimentation and filtration) • Use of specialised treatment processes (e.g. micro filtration, PAC) • Optimisation and control of operations to ensure consistent and reliable performance • Careful selection and use of water chemicals
Disinfection	<ul style="list-style-type: none"> • Choice of appropriate disinfection processes (e.g. chemical or non-chemical) • Adequate contact times for water supplies after disinfection and before supply to customers • Provision of a disinfectant residual throughout the distribution system • Consideration of disinfection by-products
Fluoridation	<ul style="list-style-type: none"> • Optimisation and control of operations to ensure consistent and reliable performance • Careful selection and use of water chemicals
Distribution system	<ul style="list-style-type: none"> • Ensure water distribution systems are fully enclosed (e.g. storages that are securely roofed with external drainage to prevent contamination) • Application of backflow prevention policies and related monitoring • Effective maintenance and monitoring procedures (e.g. for repair of faults and burst mains in a manner that prevents contamination, to control corrosion, to minimise growth or persistence of biofilms, etc) • Positive pressure throughout the distribution system • Appropriate security to prevent unauthorised access to, or interference with, water storages • Adequate training of maintenance workers, including contractors, responsible for the distribution system to minimise the potential for contamination during repairs and recommissioning

7 Example of risk methodology

Following the identification of hazards and hazardous events, relevant to each scheme associated with the service, an assessment of the risk posed by each hazard is necessary to correctly apply risk management measures. An example of an approach to estimating the level of risk is provided below. The following tables provide examples of the likelihood, consequence or impacts of risks, a risk analysis matrix and uncertainty of hazards. These tables refer to information sourced from the ADWG Appendix A5 and the SEQ Water Grid Manager.

Note: The following tables are examples only. It is the responsibility of the provider to ensure the legislative requirements are met.

Table 6: Example of qualitative measures of likelihood

Likelihood	Description
Almost certain	Occurs more often than once per week (52/yr)
Likely	Occurs more often than once per month (12/yr) and up to once per week (52/yr)
Possible	Occurs more often than once per year and up to once a month (12/yr)
Unlikely	Occurs more often than once every five years and up to once per year
Rare	Occurs less than or equal to once every five years

Table 7: Example of qualitative measures of consequence or impact

Consequence	Description
Catastrophic	Potential acute health impact, declared outbreak expected
Major	Potential acute health impact, no declared outbreak expected
Moderate	Potential widespread aesthetic impact or repeated breach of chronic health parameter
Minor	Potential local aesthetic, isolated exceedence of chronic health parameter
Insignificant	Isolated exceedence of aesthetic parameter with little or no disruption to normal operation

Table 8: Example of a qualitative risk analysis matrix—level of risk

Consequence (numbers are indicative of relative weightings)					
	Insignificant	Minor	Moderate	Major	Catastrophic
Almost certain	Medium (6)	High (10)	High (15)	Extreme (20)	Extreme (25)
Likely	Medium (5)	Medium (8)	High (12)	High (16)	Extreme (20)
Possible	Low (3)	Medium (6)	Medium (9)	High (12)	High (15)
Unlikely	Low (2)	Low (4)	Medium (6)	Medium (8)	High (10)
Rare	Low (1)	Low (2)	Low (3)	Medium (5)	Medium (6)

Table 9: Examples of degrees of uncertainty

Evaluating the major sources and types of uncertainty associated with the hazards can assist in understanding the limitation of the hazard identification and risk assessment. This table provides examples of the degrees of uncertainty and refers to information sourced from the SEQ Water Grid Manager.

Uncertainty	Description
Certain	There is five years of continuous monitoring data, which has been trended and assessed, with at least daily monitoring. The processes involved are thoroughly understood
Confident	There is five years of continuous monitoring data, which has been collated and assessed, with at least weekly monitoring or for the duration of seasonal events. There is a good understanding of the processes involved.
Reliable	There is at least a year of continuous monitoring data available, which has been assessed and there is a good understanding of the processes involved.
Estimate	There is limited monitoring data available and there is a reasonable understanding of the processes involved.
Uncertain	There is limited or no monitoring data available and the processes are not well understood.

8 Examples of operation and maintenance procedures

Operation and maintenance procedures formalise the day to day activities and help to ensure that all preventive measures are effective in managing the identified risks. While operation and maintenance procedures are usually developed to manage infrastructure related aspects of the service, these procedures may also address program areas such as stakeholder or catchment management. The following table provides examples of potential documented operation and maintenance procedures.

Note: The following tables are examples only. It is the responsibility of the provider to ensure the legislative requirements are met.

Table 10: Examples of operation and maintenance procedures

Facility	Category	Activity
All	Maintenance	Calibrating water quality monitoring and testing equipment
All	Maintenance	Commissioning of new assets (to minimise water quality risk)
All	Maintenance	Spare parts management for critical equipment
All	Maintenance	Calibration of testing equipment
All	Operation	Long-term review of water quality
All	Operation	Critical control points—monitoring, routine and corrective actions
All	Operation	Facility security
All	Operation	Incident and emergency response
All	Operation	Management of water quality data
All	Operation	Testing reagent management
All	Operation	Water quality analysis
All	Operation	Water quality sampling
Source	Operation	Blue-green algae management
Source	Operation	Catchment management
Source	Operation	Operation of water sources (priority, criteria for draw off point)
Treatment	Maintenance	Maintenance of filter media
Treatment	Operation	Chemical management—storage, handling, monitoring and ordering
Treatment	Operation	Filter backwashing
Treatment	Operation	Management of the disinfection process
Treatment	Operation	Operating treatment process units (including disinfection)
Distribution	Maintenance	Backflow prevention
Distribution	Maintenance	Inspection and maintenance of reservoirs

Facility	Category	Activity
Distribution	Maintenance	Mains cleaning
Distribution	Maintenance	Maintenance of air valves and hydrants (to minimise water contamination)
Distribution	Maintenance	Repair of main breaks (to minimise water quality risks)
Distribution	Operation	Responding to customer water quality complaints

9 References

Miller, R., Guice J. & Deere, D. (2009). Risk Assessment for Drinking Water Sources, Research Report No 78. Water Quality Research Australia Limited, Adelaide.

National Water Quality Management Strategy, Australian Drinking Water Guidelines 6, 2004. Endorsed by National Health and Medical Research Council.